

1G - Quad Port Fiber SC / Rack Mount Tap



Features

- Passive Monitoring
- No Point of Failure
- No power required
- Invisible to the network
- 3 years warranty

Order Number

F4S-*-**

The Fiber Optic Tap avoids downtime in your network. Easy to install, fault tolerant and transparent to the network. Passive and none powered it does not introduce a point of failure.

It monitors traffic at maximum wire speed. Invisible to the network, none intrusive, and copies all 7 layers. It offers a perfect and cost effective solution to tap networks for IDS (security), SNMP (management), RMON (remote) and Protocol analysis.

The Tap is none intrusive for 100% security. They are transparent to the network and cause no point of failure.

High Quality (low loss) Zirconia sleeve adapters are used in both Multi and Single Mode models.

Order information :

Base Product #	Fiber type	Split ratio (Network)
F4S	- E U S	- 50 60* 70* 80* 90*

*Please contact us for availability

E = MM 50/125µm
U = MM 62.5/125µm
S = SM 9/125µm

Optional accessories



19" Rack Plate 1U (ARP1U-1M)



Filling Plate (AFP1U)

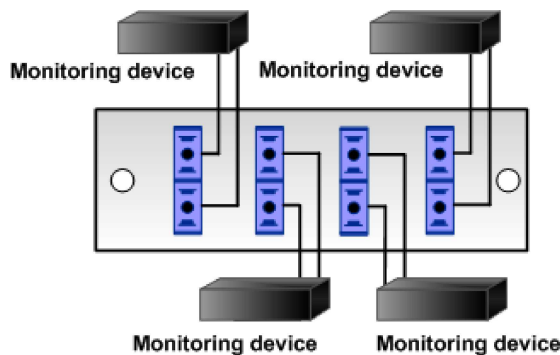

Front view

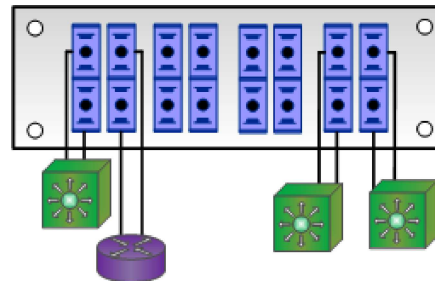

Back view

Unit in rigid metal housing, black oven painted.
Containing 4 x 2 couplers
12 duplex SC Zirconia sleeve connectors.
Operating Temperature : 0 to 55°C
Storage Temperature : -10 to 90°C
Humidity : 10 to 90%, non-condensing.
Dimension (WxDxH) : 14.3 x 11.2 x 4.1 cm
Weight : 595gr

Maximum Insertion Loss (dB) :

Split ratio	50/50	60/40	70/30	80/20	90/10
MultiMode 50/62.5µm	4.4/4.4	3.1/5.0	2.4/6.3	1.8/8.1	---
SingleMode 9µm	3.7/3.7	2.8/4.9	2.0/6.1	1.3/8.0	0.8/12.0

Multi Mode 50/62.5µm...Dual Wavelength 850/1300 nm
MultiMode 10Gb/50µm...Wavelength 850 nm
Single Mode : Dual Wavelength 1310/1550 nm